



MODEL C-RD-T

CEILING DAMPER SQUARE AND RECTANGULAR

U.L. 555C CLASSIFIED ASSEMBLIES AND ULC S112.2 LISTED

Approved for Assembly ratings of 3-hours or less

Application and Design

The Model C-RD-T is a square neck diffuser to a round duct, UL classified ceiling (radiation) damper, butterfly style approved for both steel duct, and flex duct installations in approved UL ceiling designs that incorporate/show a hinged door damper requiring fire/heat protection where HVAC components penetrate the ceiling membrane. These dampers provide protection up to 22" x 22" (559mm x 559mm) diffuser opens and an 18" (457mm) diameter duct opening.

Standard Construction

Frame: Roll formed. - 22 Ga. Galvanized Steel

Blades: 22 Ga. - Galvanized Steel, un-insulated 9 X 9 (81 sq in.) and under with U.L. Classified Insulation over 9 X 9 (81 sq in.)

Spring: Corrosion resistant steel spring.

Fusible Link: Replaceable 212°F (100°C) standard (others available)

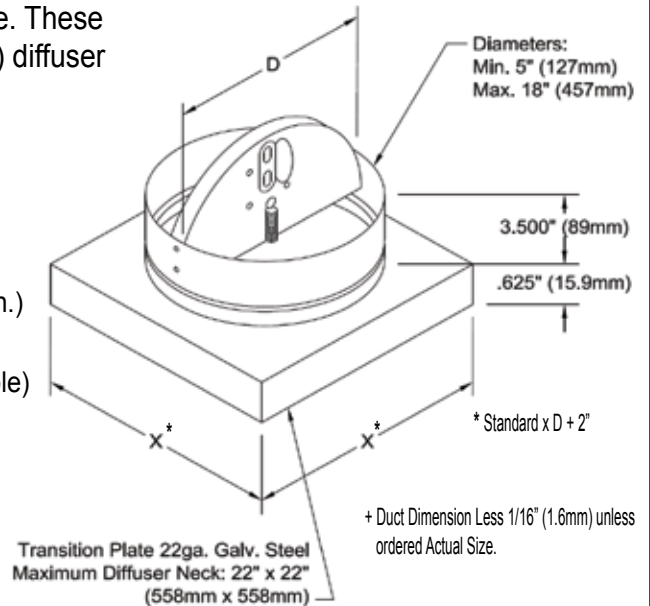

Extended Frame Table*	
Size (D)	Frame Depth (H)
5" to 10" (127mm to 254mm)	6-3/4" (171mm)
11" to 14" (279mm to 356mm)	8-3/16" (208mm)
15" to 18" (381mm to 457mm)	11-3/4" (298mm)

Standard Sizes (duct)	
Min. Size	Max. Size
5" Diameter (127mm)	18" Diameter (457mm)

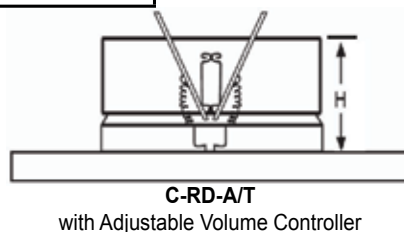

Options:

- Volume Adjustment
- Thermal Blanket - 1/8" thick (24 X 24) - CK2000-1 (Required on surface mtd. diffuser larger than 1" in any direction of diffuser neck opening)
- Alternate Thermal Blanket 1 1/4" Batt (24X24) CK-2000-1B (Required on t-bar or surface mtd. diffuser larger than 1" in any direction of diffuser

Designed and tested in accordance to standards: UL 555C, ULC S112.2. Labeled and listed by UL/ULC under File #R27747. They meet all the NFPA-90A, IBC Code, and other major code

SUGGESTED SPECIFICATION

Square to round ceiling dampers shall be Model C-RD-T or C-RD-A/T by CVS. Ceiling dampers shall bear the Underwriters' Laboratories label and be rated for both steel duct and flex duct installations. No external damper supports shall be required for ceiling dampers up to and including 18" (457mm) diameter. Ceiling dampers shall be of the non-asbestos type and be furnished with a fusible link volume controller where shown (Model C-RD-A/T).

Manufacturer's Recommendations

All moving parts of the damper must be inspected and cycled once the first year and at intervals not greater than every 4 years or in accordance with the latest edition of NFPA 90A, 92A, local codes and the manufacturer. In addition, fuse links shall be removed and inspected for corrosion. Dry lubricants are recommended.

Job Name:
Location:
Architect:
Engineer:
Contractor:

MODEL C-RD-T